

PARTS LIST				
ITEM	PART NUMBER	DESCRIPTION	MASS	QTY
1	101-9501050-FAB	950/1050 SPREADER BEAM	30.5 kg	1
2	591-5500260-000	25mm BOW SHACKLE GRADE 'S'	2.2 kg	3
3	591-5500230-000	16mm HAMMERLOCK	0 kg	4
4	591-5500221-000	16mm LIFTING CHAIN x 8 LINKS GRADE T	2.1 kg	2
5	591-5500255-000	22mm BOW SHACKLE GRADE 'S'	1.8 kg	2
6	100-1003455-FAB	1.5T SAFE-T LIFT - EXTENDED SHAFT	19.3 kg	2
7	102-9001100-FMAN	SAFE-T LIFT JAW INSTALLATION AND REMOVAL MANUAL	0 kg	1

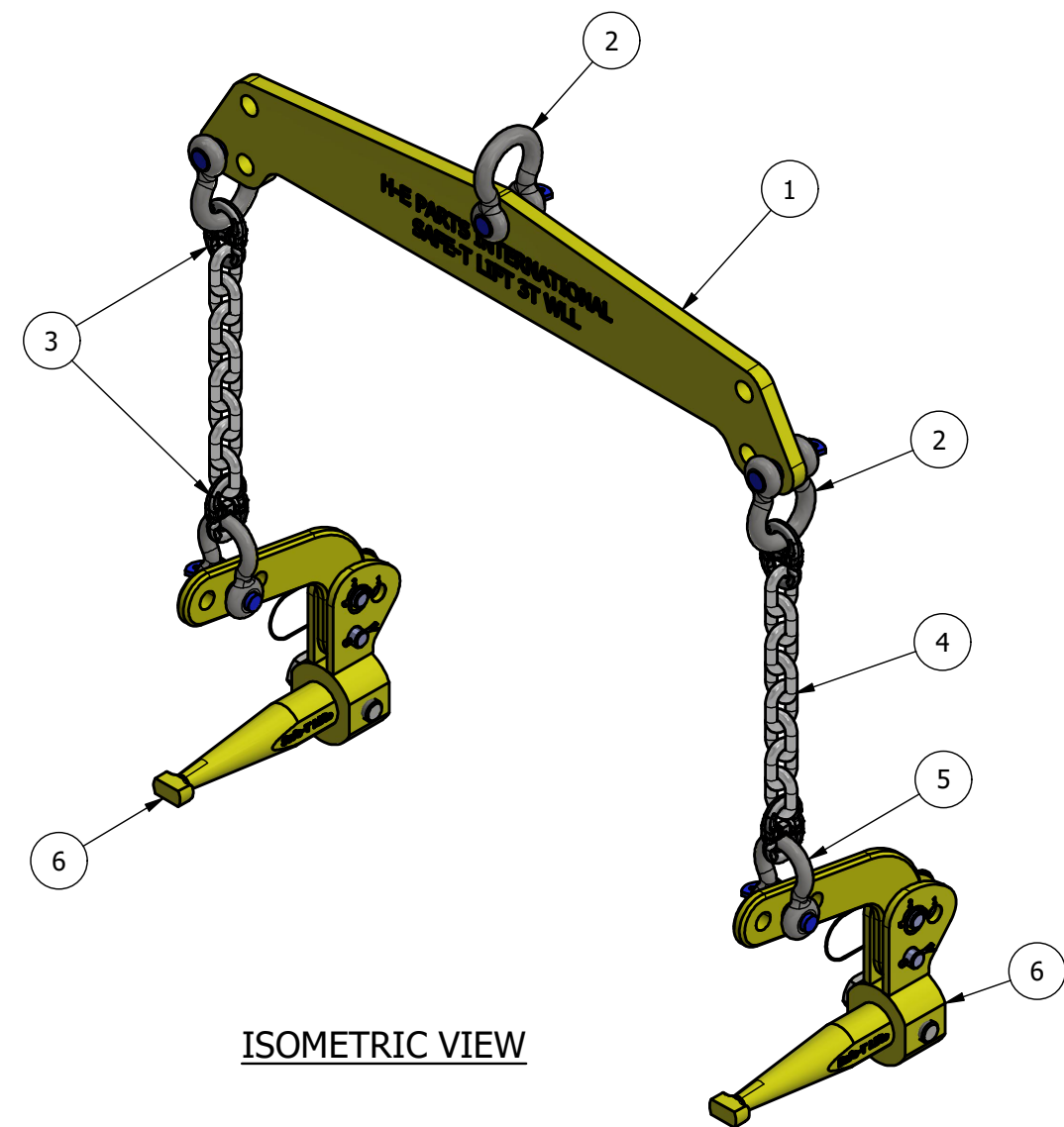

ISOMETRIC VIEW

LOAD TESTING NOTES:

LOAD TESTING DONE TO AS4991-2004
 PROOF TEST LIFTING ASSEMBLY TO 78.5kN
 AND STAMP "WLL 3 TONNES"

H-E PARTS INTERNATIONAL
 CRUSHING SOLUTIONS
 Perth - Head Office T +61 8 9410 4400
 Cnr Lee Rd and Macedonia St F +61 8 9410 4499
 Naval Base, Western Australia perth@crushingandmining.com.au
 Australia 6165 www.crushingandmining.com.au

THIS DRAWING AND ALL INFORMATION CONTAINED HEREIN IS TO REMAIN THE PROPERTY OF H-E PARTS INTERNATIONAL CRUSHING SOLUTIONS AND MUST NOT BE USED FOR ANY OTHER PURPOSE THAN THAT FOR WHICH THE DRAWING IS SUPPLIED, WITHOUT WRITTEN PERMISSION FROM CRUSHING AND MINING EQUIPMENT. THIS INFORMATION IS STRICTLY CONFIDENTIAL.

MATERIAL:	REFER TO P/LIST	SCALE 1:7.5	INIT DRN BMC 23/09/2021	DATE 23/09/2021	TITLE: 3T WLL SAFE-T LIFT 950/1050 LIFTING ASSEMBLY COMPLETE ASSEMBLY
FINISH:	ASSEMBLED	TOLERANCES U.N.O. - CASTING: - ISO 8062-2 GRADE CT10 - MACHINING: - ISO 2768-m - ANGULAR: - ISO 2768-m	CHK DF 23/09/2021	APPR DF 23/09/2021	
APPROX. WEIGHT:	83.7 kg	ALL WELDING TO AS1554.1-GP STANDARD	GENERAL FINISH:- CASTING: 12.5 MACHINING: 6.3		
JOB No:	8813	ISSUE No:	621582	SHEET No: 1 OF 1	PART No: 102-9001100-EFAB
					REV: 0